



90奈米製程下運用於量子電腦鎖相迴路的壓控震盪器

A 90nm Voltage Control Oscillator For Quantum Computer's Phase-Locked Loop

組別：B451 組員：王芑鈞、陳世衡 指導教授：徐碩鴻

Introduction

This project focuses on designing a high-performance VCO using an improved Capacitor bank(Cap. bank) switch and Class-C architecture to achieve wide tuning range, low phase noise, and high power efficiency. By addressing the limitations of traditional designs, this work enhances tuning range without increasing phase noise and reduces power consumption, making it suitable for high-frequency applications like quantum computing.

Design Flow

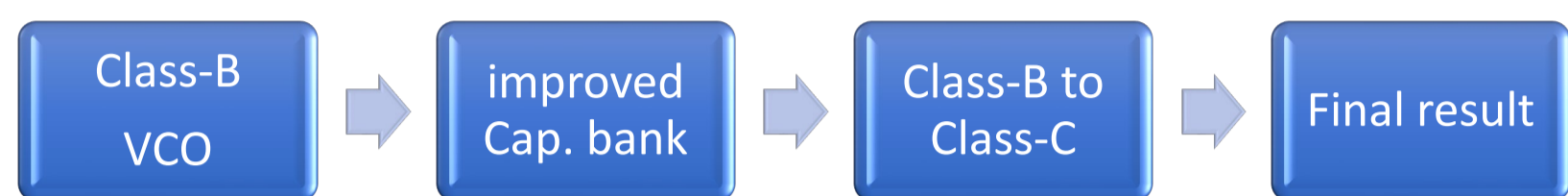

- (1) verify performance under different cap. bank structure
- (2) Class-B VCO v.s push-pull Class-C VCO
- (3) performance validation, then determine final structure

Varactor Choice

A varactor adjusts resonant tank capacitance via MOSCAP control voltage to tune frequency but has limited tuning range and linearity, leading to alternative solutions.

Cap. bank – differential switched-tuning circuit

The original Cap. bank structure uses two NMOS transistors as loading, introducing r_{ds0} which degrades the quality-factor(Q-factor). The improved design, with symmetric transistors, doubles the Q-factor for the same MOS size.

Inverters consume no static power and have a small footprint, improving both Q-factor and power efficiency compared to the original design.

This stage confirmed that using the differential switched-tuning circuit effectively enhanced tuning range and suppressed phase noise, making it the better choice for the final VCO design.

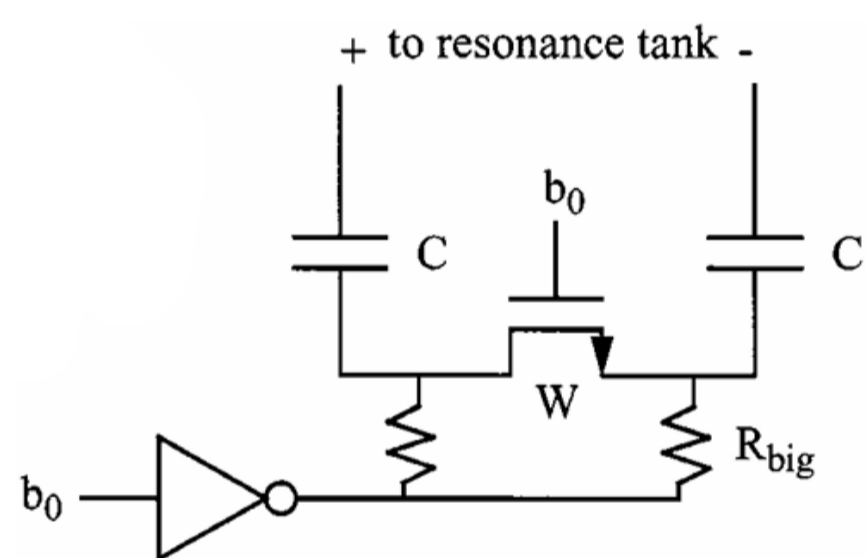
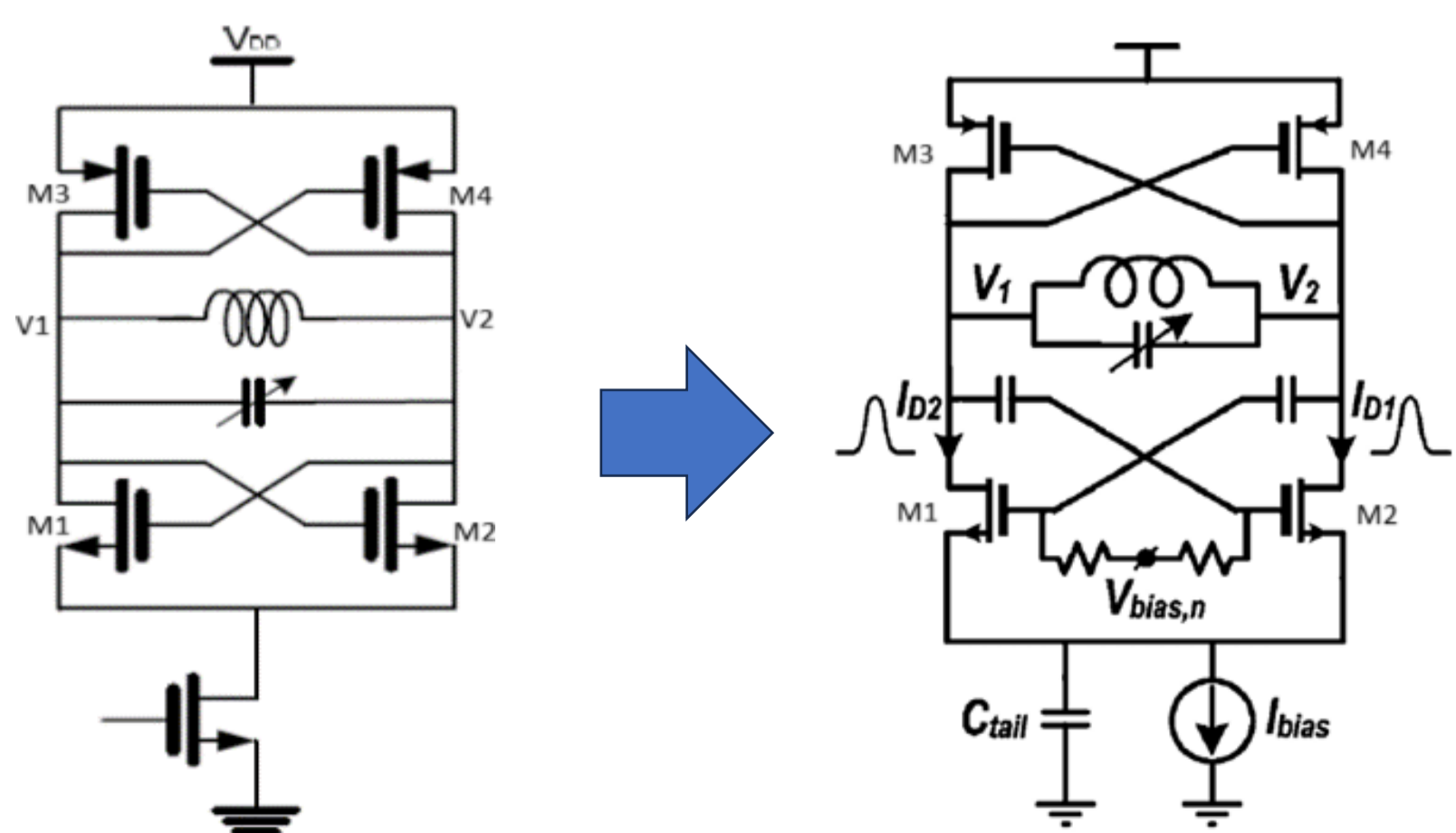

Fig. improved cap. bank

Class-B v.s Push-Pull Class-C

Class-B VCO offers better linearity between control voltage and output frequency, enabling more precise frequency tuning.

The improved phase noise of the Class-C push-pull VCO results from optimizing NMOS and PMOS, reducing phase noise by controlling current flow during a shorter part of the oscillation cycle.



Class-B(push-pull) VCO

Class-C push-pull VCO

The Class-C push-pull VCO, with its pulse-like I_{ds} waveform, shorter conduction time, and smaller conduction angle, provides better DC-to-RF conversion,

Final Result

result – tuning range

The tuning range at 15GHz shows that using the Cap. bank increases the range by 1.5 times and improves KVCO stability compared to the varactor-only design.

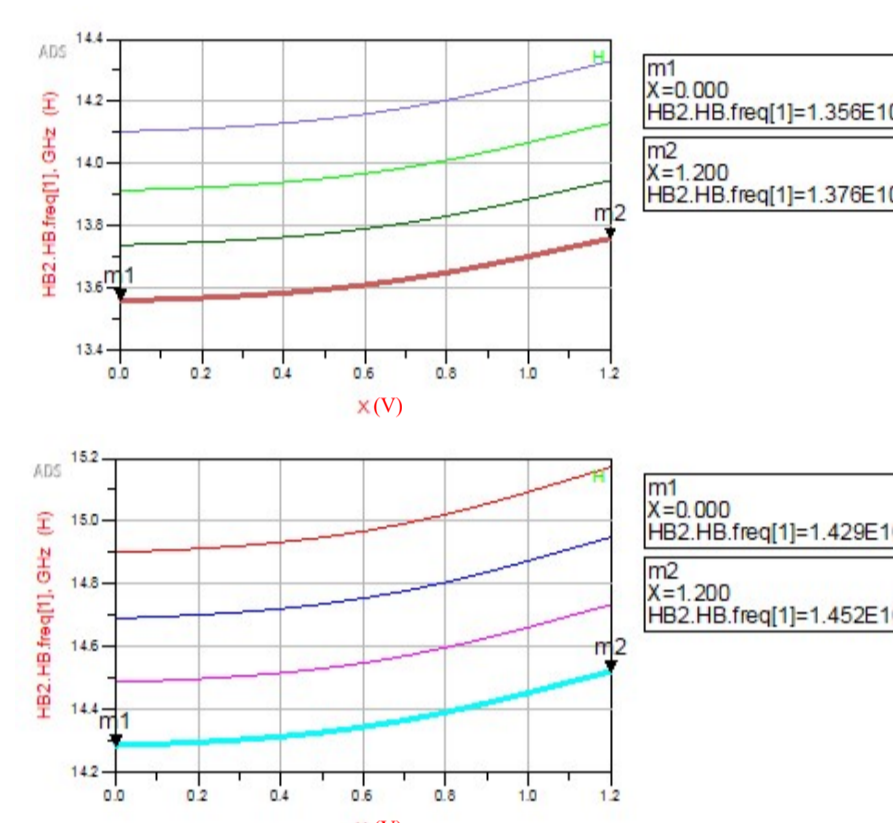

result – voltage oscillation

The upper chart on the right shows VCO output amplitude is 0.3V, with LC tank oscillation limited to VDD; the lower chart confirms MOS operation in saturation with a pulse waveform, as in Class-C.

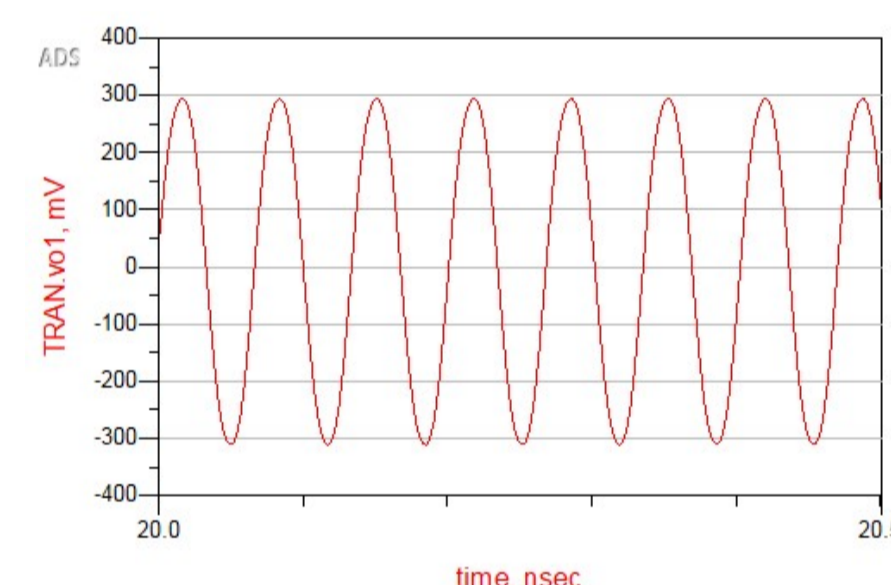

result – phase noise

The buffer in the final design introduces slight noise, affecting phase noise. However, with significant improvements in frequency and tuning range, the phase noise remains within an acceptable range, meeting our design goals for high-frequency performance.

specification

VDD(V)	1.2
Total current(mA)	1.5
Power(mW)	1.8
frequency(GHz)	13.56~15.17
Phase noise(dBc/Hz) (@1MHz offset)	-100.549
FOM(@15GHz)	-182.19

Conclusion

This project validates a two-phase approach: the Improved Differential Switched-Tuning Circuit effectively enhances tuning range while controlling phase noise, and the Class-C VCO reduces phase noise and power consumption. Combining these advantages, we developed a high-performance VCO architecture, appropriate for high-frequency systems and suitable for quantum computer PLL modules, ensuring low power and stable quantum states.